



PROVIDING TURN-KEY SOLUTIONS TO AUTOMOBILE INDUSTRY

- Special Purpose Machines (SPMs)
- Robotic Cells
- Complete Manufacturing & Testing Line for
- Exhaust Systems
- Automotive Seat Frames
- Cross Car Beam
- Farm Equipment Fixtures



Additional set of tooling

Dual Station Auto Multispot Welder for Exhaust Muffler & Baffle



Lap Seam Welder / Series Line Seam Welder
Please refer separate catalogue.

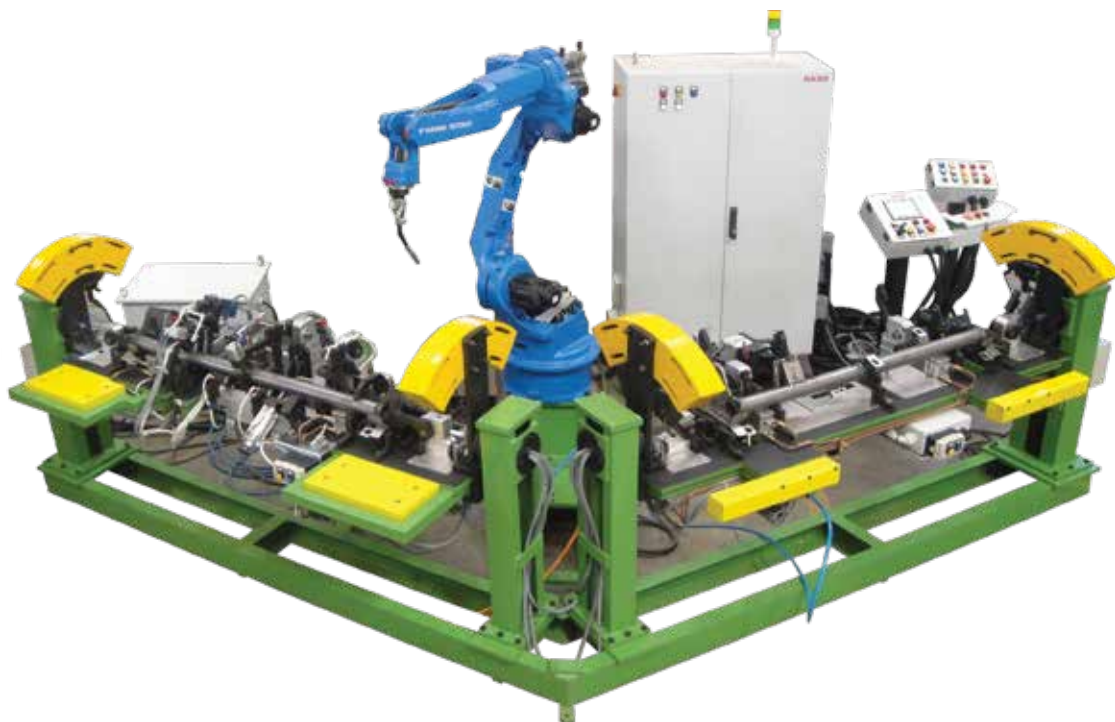

Robotic CO2 Welding Station for CCB (For SUV)

Turnkey Robotic Welding Line for Cross Car Beam (CCB) for passenger car including Sheet Metal Components from Group Company CEARS

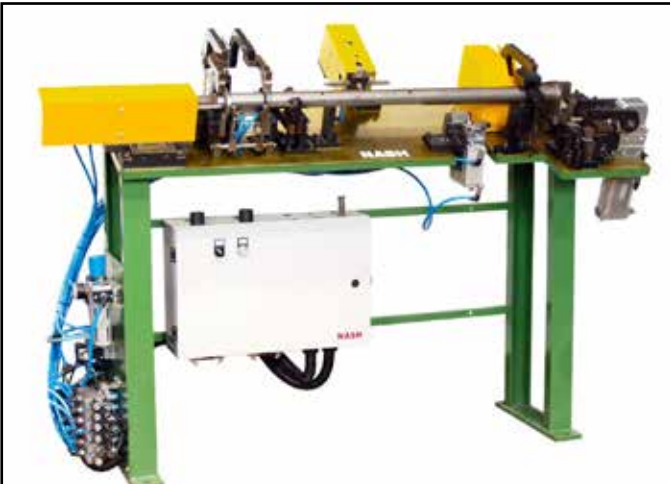

Manual Tack welding fixture for pierce tube + side Brackets + Baffles (OP-01)



Circular Welding SPM with 03 torches for welding of output from OP-01 (OP-10)

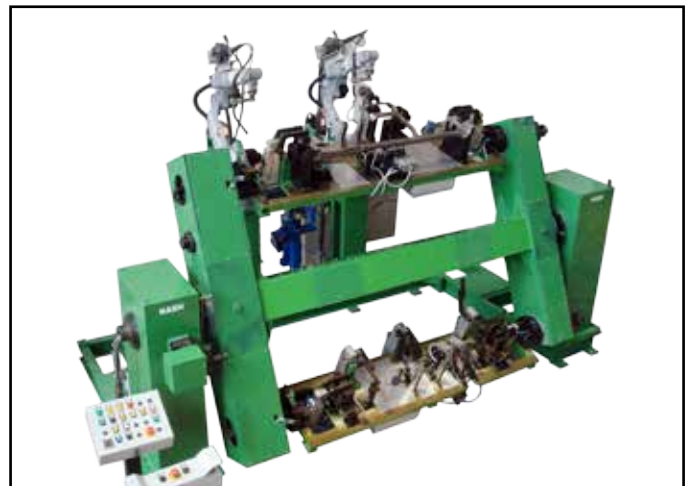

Robotic CO2 Welding Fixture with Servo driven H pillar for S/A OP-20 + S/A OP-30 & other child parts (OP-H40A + OP-H40B)



Robotic CO2 Welding fixture with Hydraulic clamps (+ Pneumatic turn table) for output of OP-10+SMBC tube (OP-20)



Manual Stud Welding Fixture (OP-50)



Manual Tack welding fixture for Centre Lug Assembly (OP-30)



Final Output Component (CCB)

Earth Moving Equipment



Hoe Bucket, Welding Fixture
L X W X H : 3100 X 1650 X 1300 MM

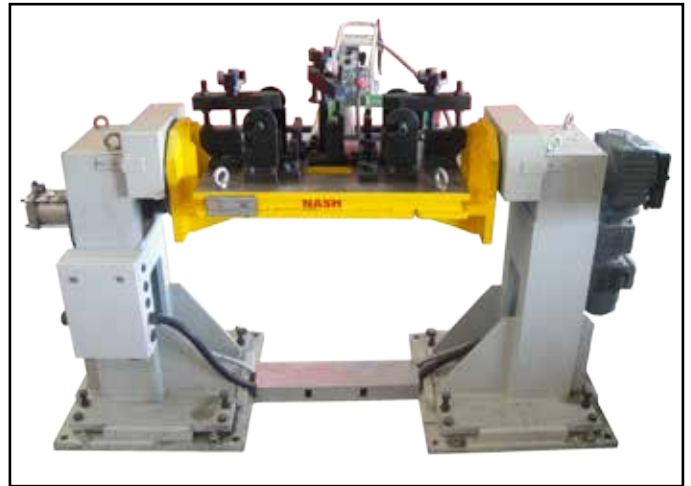

Loader Bucket Fulcrum Sub Assembly

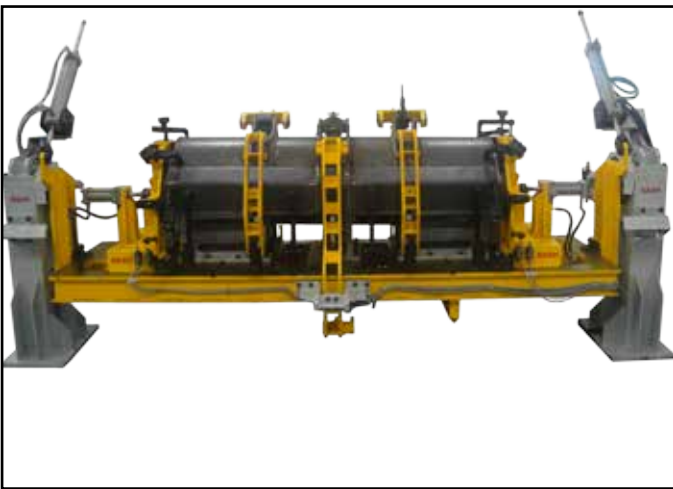

Loader Bucket, Hydraulic Indexing Fixture
L X W X H : 5200 X 1900 X 2400 MM



Loader Bucket
Size : 2400 x 750 x 890 mm, Weight : 485 Kgs.

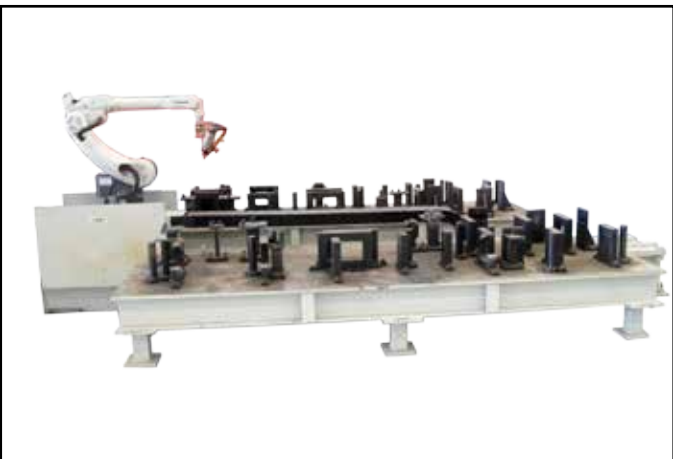

Robotic Plasma Cutting Jigs

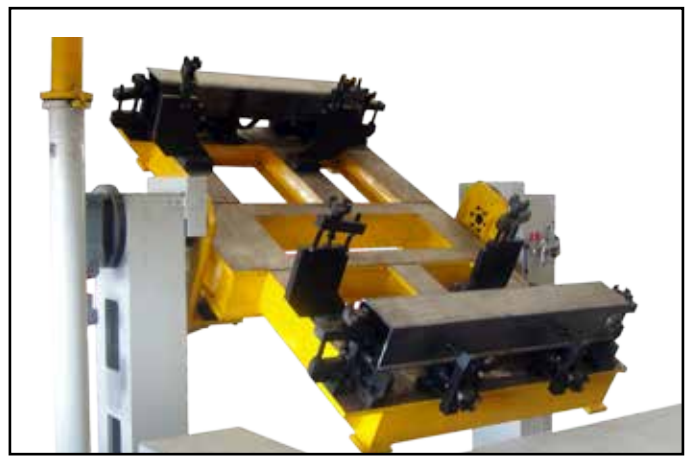

Main Frame Welding Fixture with Indexing



Main Frame Sub Assembly
L X W X H : 1000 X 800 X 950 MM, Weight 150 Kgs.



Base Structure Assembly
Size : 2800 x 1800 x 1300 MM



Pivot Assembly

WELDING FIXTURES & INSPECTION JIGS FOR AUTOMOTIVE SEAT FRAMES



Spot Welding Machine with self equalising tooling

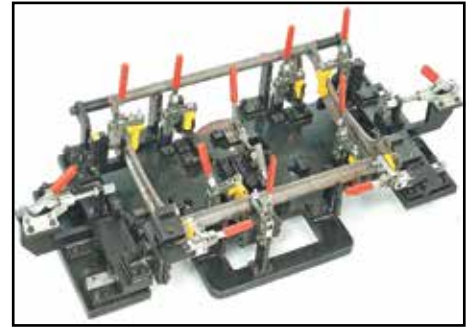

Fixture inspection by portable CMM

FIXTURES & INSPECTION JIGS FOR CROSS MEMBER ASSEMBLY AND LOWER ARM.

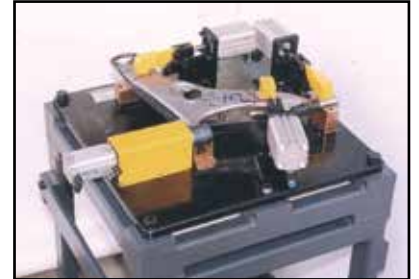
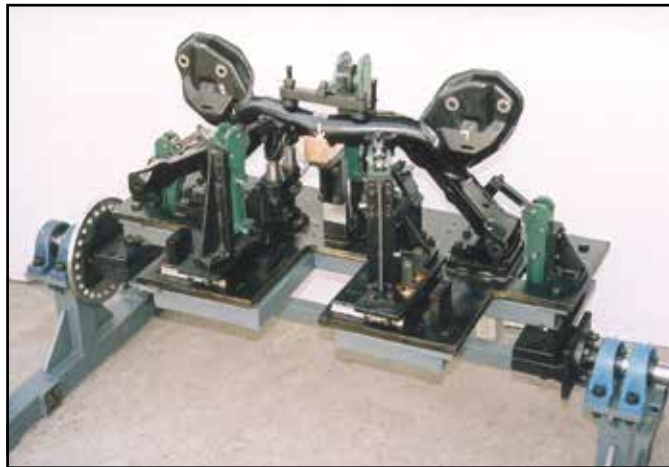

- Welding Robot - 16 Nos.
- Material Handling Robot - 01 No.
- Welding Fixtures - 33 Nos.
- Inspection Jigs - 04 Nos.
- Pick-Up Jig - 01 No.
- Final Assembly Fixture - Fully Automatic Welding Control thru PLC including loading and unloading

EQUIPMENT FOR EXHAUST SYSTEMS

Turnkey Solutions - Press Parts / SPMs / Robotic Lines

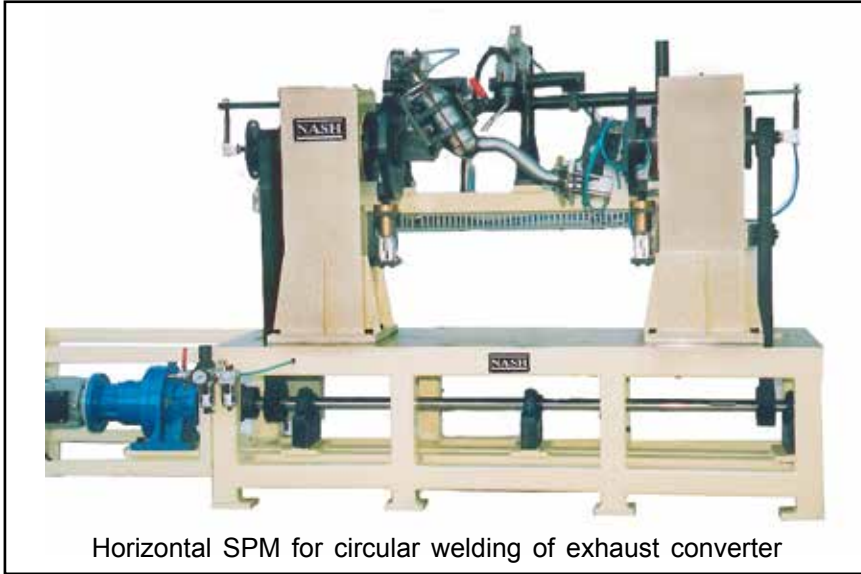

Horizontal SPM for circular welding of exhaust converter



Dual Torch CO₂ Welding SPM for Catalytic Converter Assembly with In & Out Flanges



Dual Torch CO₂ Welding SPM for Resonator Assembly with In & Out Pipe

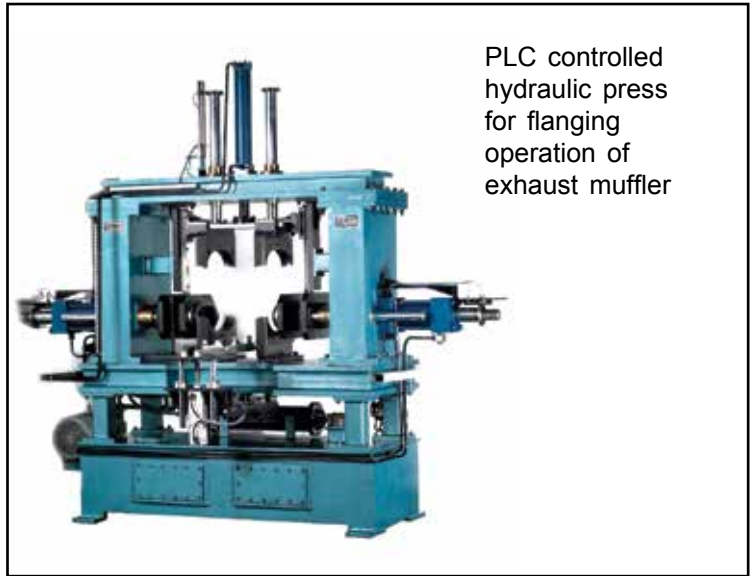

PLC controlled hydraulic press for flanging operation of exhaust muffler



Special Purpose Spot Welder for Seat Frame Lower Sliding Bracket

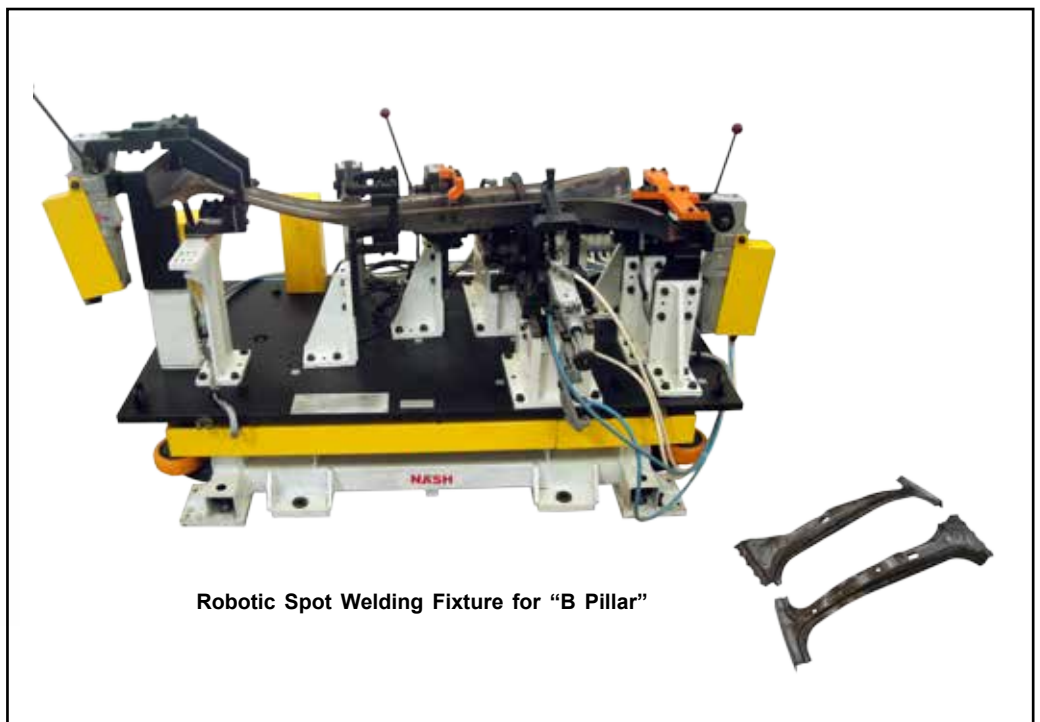

Robotic Spot Welding Fixture for "B Pillar"



Roof Spot Welding SPM for Traveller



Specially designed for 3 variants
 Auto variant detection
 Dual indirect spot system
 Pendant Teaching facility
 Servo Driven Head for curvature spot



Servo Indexing Multi **Spot Welder** with self equalizing Spot Welding Auto Guns for Back Plate and Dust Shield welding for Automobile Brakes.



Underbody Auto Spot Welder Dual Height



Projection Welder for Oil Pan

Specially designed for sandwich sheet separated by insulated intermediate layer
 Internal sliding electrodes.

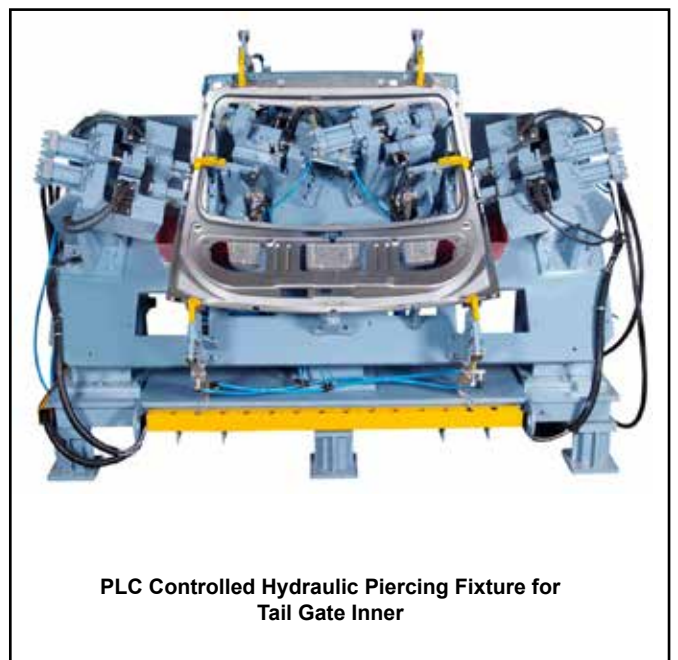

PLC Controlled Hydraulic Piercing Fixture for Tail Gate Inner



Auto Multispot (06 spot) Welder System for Door after Hemming Operation.



Robotic Welding Cell & Fixtures for Rear & Front Door Hinges



Multi Spot Welder for Door Sash LH & RH



ROBOTIC WELDING AUTOMATION For TWO WHEELER SWING ARM ASSEMBLY



Battery Terminal Post Burning Machine



ROBOTIC WELDING AUTOMATION For TWO WHEELER Fuel Tank ASSEMBLY



Indexing type Multiprojection welder for Water Impeller Assembly



Flash Butt Welder



Indexing Brake Shoe Projection Welder, Brakes India

BIW Fixtures from group company PMA Automotive

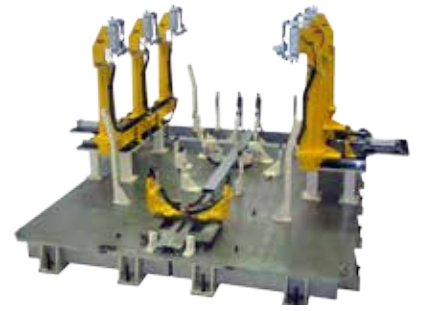

NASH reserves the right to change specifications and appearance without prior notice.

NASH Robotics and Automation Pvt. Ltd.

93/9, MIDC, Satpur, Nashik 422 007, India

Phones : +91 - 253 - 2353382, 2352180, 2350680

Fax : +91 - 253 - 2351780

Email : co@nashrobotics.com

Web : www.nashrobotics.com

ISO 9001

